

DIY Kit 130. Door Minder

INTRODUCTION

This kit uses an infrared (IR) beam to monitor door & passage-ways or any other area. When the beam is broken a relay is tripped which can be used to sound a bell or alarm. Suitable for detecting customers entering a shop, cars coming up a driveway, etc. The IR beam is very strong. Distances over 25 yards can be monitored with this Kit. A 12VDC unregulated supply is required to power the kit. A 12V wall adaptor is fine. Provision has been made so that only one power supply needs to be used to power both units. The relays in this kit are rated to switch mains voltages.

The kit is constructed on single-sided printed circuit board. Protel Autotrax & Schematic were used in the design.

CONSTRUCTION

The kit is built on two separate PCBs – a transmitter PCB (K130T) and a receiver PCB (K130R). Refer to the parts list to see which components belong to which board. Use the component overlay on each PCB to place the components.

Transmitter board

Insert the lowest height components first. Leave the infrared LED and power jack until last. Make sure that the electrolytic capacitor and diode are inserted correctly. A socket is supplied for the IC.

The IR LED can be mounted vertically or at right angles to the PCB. This will depend on how the transmitter will be mounted when in use. In either case the LED must be inserted the right way round. The flat edge on the LED should line up with the flat edge on the PCB overlay.

Lastly, if the distance to be monitored is less than about 10 yards then you will need to fit the 5mm tubing over the IR LED. This narrows the radiating angle of the IR beam and makes it much more directional. The IR output is strong. It can easily bounce off walls etc to give false readings.

Receiver board

As with the transmitter board, start with the lowest height components first - resistors, diodes, capacitors and transistors. Note the polarity of the electrolytic capacitors and diodes. Next insert the screw terminal block, power jacks and relay. Last of all is the infrared receiver module. The orientation is clearly shown on the PCB overlay.

CIRCUIT DESCRIPTION

Transmitter Board

The transmitter board consists of two oscillators, one running at approx. 250Hz and the other running at 38KHz. The 38KHz frequency acts as a carrier wave and is required by the IR receiver module on the receiver board. This carrier wave is “ANDed” or modulated with the 250Hz frequency to produce an output signal that contains bursts of 38KHz at a rate of 250Hz. This signal is used to drive an infrared LED.

The oscillators are made using a 4093 quad 2-input NAND gate IC. One gate, IC1:D, is used for the 250Hz oscillator. Resistor R1 and capacitor C1 set the frequency. Another pair of gates, IC1:A and IC1:B, make up the 38KHz oscillator. Resistors R2 and R3 and capacitor C2 set the frequency. Gate IC1:C “ANDs” these signals together.

Transistor Q1 provides a constant current source for the IR LED. The zener, Z1, on the base of Q1 keeps the emitter at a constant voltage. Therefore the voltage across R6 is also constant. For the values shown the current through the LED, when on, is fixed at approx. 85mA. The peak current through the LED is set by R7 and determines the range of the kit. Reduce it to say 22R to get greater range if needed.

Receiver Board

The receiver consists of an IR receiver module that detects the incoming IR beam. The IR signal is used to keep a capacitor charged which in turn holds a relay operated. When the beam is broken the capacitor discharges and the relay releases.

The IR detector module, RX1, is made up of an IR LED and an amplifier/filter circuit tuned to detect a 38KHz frequency. The output pin is low whenever a 38KHz signal is detected. Pinout: looking at the unit bubble to you – left pin Vout, center pin Ground, right pin Vcc.

When the IR beam is present the relay is operated.

The output of RX1 is the 250Hz signal from the transmitter. This signal is passed via transistor Q1, capacitor C1 and diode D2 to capacitor C2.

C2 is fully charged during the high portion of the signal. It starts to discharge during the low portion of the signal via LED L1, resistor R4 and transistor Q2. However the discharge time is much longer than the off time of the signal so the voltage across C2 is always enough to keep transistor Q2 on and therefore the relay operated.

When the beam is broken the output of RX1 is high. Transistor Q1 is off and capacitor C2 is no longer being recharged. It will eventually discharge to the point where transistor Q2 will turn off and the relay will release.

The “turn off” delay is determined by the time constant of resistor R5 and capacitor C3. With the values used it is approximately half a second.

Capacitor C1 prevents a steady DC voltage on the collector of Q1 from charging C2. This would occur if the beam was not present or the beam was a continuous 38KHz signal. In other words, the receiver module will only respond to a pulsed 38KHz signal.

DIY Kit 130. Door Minder

LED L1 gives a visual indication when the IR beam is present and is used to help with installation and setup. It can, of course, be removed if it is not wanted.

Zener diode Z1, resistor R6 and capacitor C4 provides a stable 5.6V supply for the IR module. The relays provided with this kit are mains rated but use with care. RUDH 110V/10A; RWH 250V/12A, 120VAC/15A.

INSTALLATION

For ease of operation, the transmitter board can be powered from the receiver board when they are relatively close together. Two plugs have been supplied for this. Connecting wire for the length required must be supplied by you. Otherwise two separate power supplies are required.

The receiver board contains two DC jacks connected in parallel. Power from a 12VDC source is connected to one jack. A lead can then be connected to the other jack and run to the transmitter board. DC plugs to make up a lead are supplied with the kit.

Aligning the transmitter and receiver is simply a matter of pointing the transmitter IR LED at the receiver board and moving it around until the red LED on the receiver board lights. This indicates that the beam is being received. The relay will be operated.

Note:

With power applied the relay is normally operated and only releases when the beam is broken. The relay contacts labelled "NO" (Normally Open) and "NC" (Normally Closed) refer to when the relay is released.

With the relay operated, the "NO" contact will be connected to the "C" contact and the "NC" contact will be unconnected.

IF IT DOES NOT WORK

Poor soldering ("dry joints") is the most common reason that the circuit does not work. Check all soldered joints carefully under a good light. Re-solder any that look suspicious. Check that all components are in their correct position on the PCB. Are the electrolytic capacitors and diodes the right way round? Have you fitted the 5mm tubing over the IR LED on the transmitter board?

Web Address & Email

You can email us at peter@kitsrus.com

See our website at

<http://kitsrus.com>

This is an improved (naturally!) version of the door minder published in *Silicon Chip*, april, 1999. It was developed originally by Oatley Electronics.

PARTS LIST – K130

Transmitter board

Resistors (0.25W carbon)

47 yellow violet black.....R6.....	1
1K brown black red.....R5.....	1
1K8 brown grey red.....R3.....	1
6K8 blue grey red.....R2.....	1
47K yellow violet orange.....R1,4.....	2

Capacitors

1nF ceramic 102.....C2.....	1
100nF monobloc 104.....C1.....	1
100uF 25V electrolytic.....C3.....	1

Semiconductors

4.7V 400mW zener diode.....Z1.....	1
BC557 transistor, PNP.....Q1.....	1
4093 CMOS IC.....IC1.....	1
Quad 2-input NAND with schmitt trigger inputs	
IR LED, EL-1L7.....L1.....	1

Miscellaneous

2.5mm DC jack.....X1.....	1
Tubing, 5mm x 25mm long to fit over L1.....	1
PCB, K130T.....	1

Receiver Board

Resistors (0.25W carbon)

470 yellow violet brown.....R3,6.....	2
6K8 blue grey red.....R1,2,4.....	3
47K yellow violet orange.....R5.....	1

Capacitors

10uF 16V electrolytic.....C1,2,3.....	3
100uF 25V electrolytic.....C4,5.....	2

Semiconductors

1N4148 signal diode.....D1,2.....	2
1N4004 power diode.....D3.....	1
5.6V 400mW zener diode.....Z1.....	1
BC547 transistor, NPN.....Q2.....	1
BC557 transistor, PNP.....Q1.....	1
LED, 5mm red.....L1.....	1
IR receiver module.....RX1.....	1
PIC-12043S	

Miscellaneous

2.5mm DC jack.....X1,2.....	2
Terminal block, 3-way.....X3.....	1
Relay, 12V SPDT.....RL1.....	1
"Goodsky" RWH-SH-112D, or RUDH-SS-112D	
PCB, K130R.....	1

Extras

2.5mm DC plugs.....	2
(to make up optional power lead to the transmitter board)	

DIY Kit 130. Door Minder

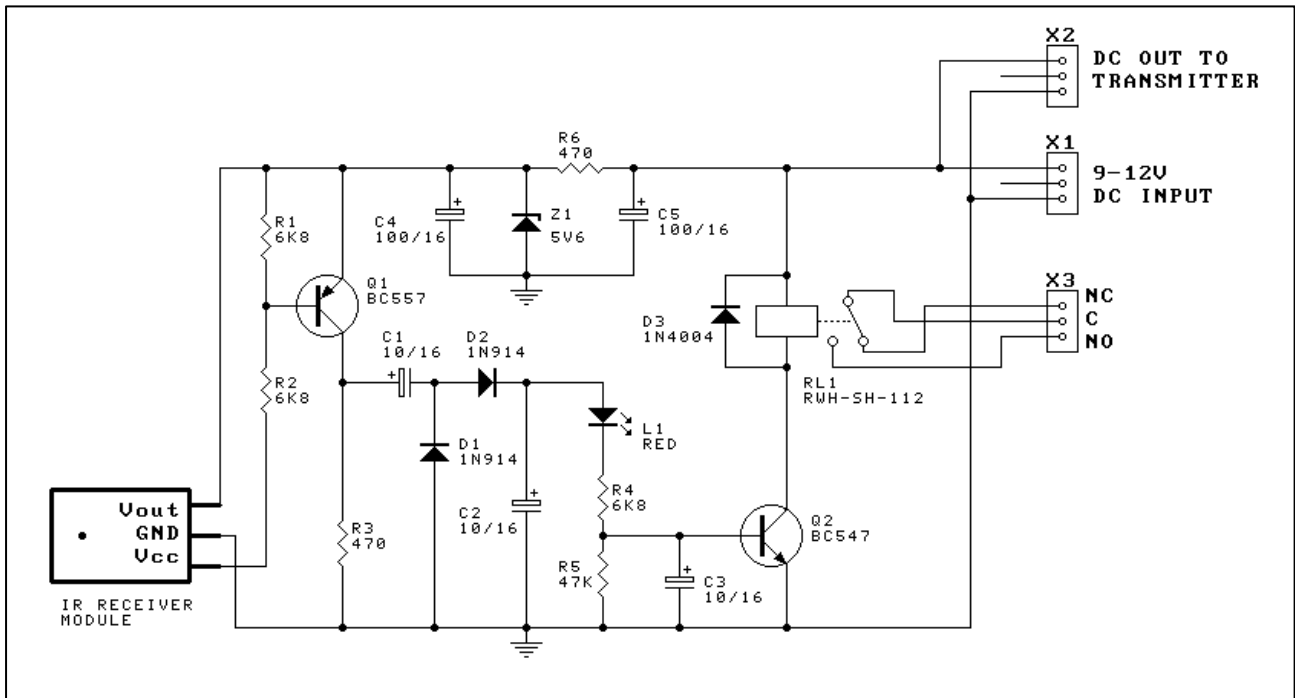

Door Minder - Receiver Module

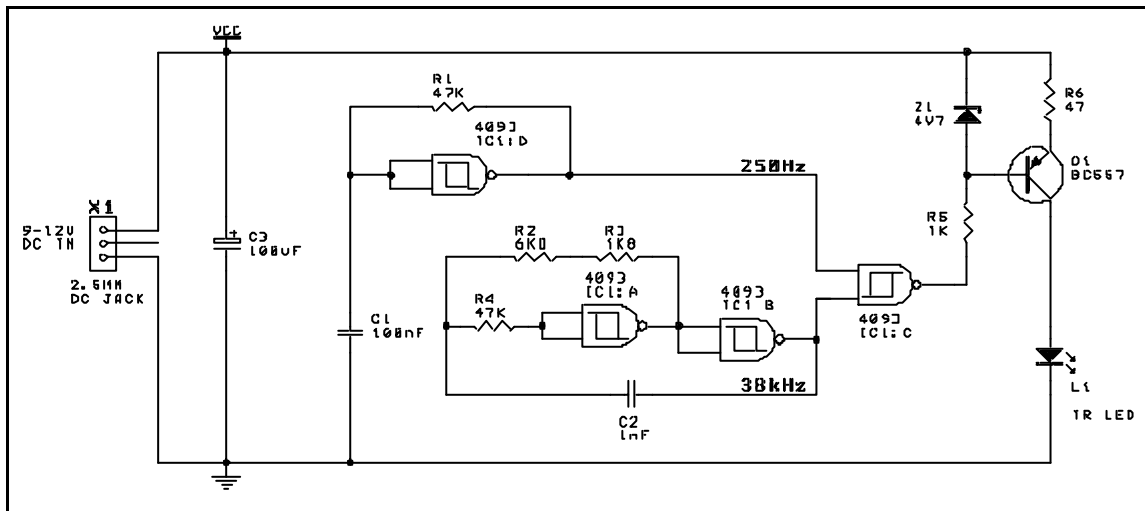

Door Minder - Transmitter Module