

KIT 118 12BIT DATA ACQUISITION SYSTEM

November, 1999. Please download the latest software and documentation for this Kit from my website at

<http://kitsrus.com/soft.html>

At 3.9MB it is too big to distribute on floppy disk. (The same software may also be used for Kit 112).

You may download the documentation-only separately.

Previous versions of the software and documentation are also available.

This kit was published in *Electronics Australia*, january 1997, 64-67. However, bith the software and the hardware have progressed since that time.

Assembly

Please read all these instructions through once before starting assembly. First note that 4 components are mounted **underneath** the double sided, plated through PCB. The overlay shows these components but they are mounted **UNDERNEATH** the board on the copper side of the PCB. The 4 components are C7 C8 R5 & R2. C7, the 10uF tantalum capacitor must be pushed over on its side so that the total height from the surface of the PCB is under 5mm (otherwise it will not fit inside the case.) The ceramic capacitor, C8, also needs to be pushed over a little. The 1/8W resistors will be under 5mm above the board.

All the other components are on the top of the PCB as normal. Again the tantalum capacitor must be pushed over to be under 5mm high. Make sure to identify C6, the 103 monoblok capacitor and get it in the right position. Make sure also that the two 10 pin IC's are soldered in the right positions. U2 is the MAX186. Note the orientation of the 1N4148 diode. The 78L05 must be mounted **flush** on the PCB so it is not above 5mm. The resistor networks can be either way around.

Make sure that the two DB25 connectors are correct: **J1 is male, J2 is female**. Use one half of

the case as a jig to hold the connectors & the PCB **before** you solder any lugs. If you do not do this then you run the risk that a connector will be skew on the PCB & not fit properly into the case at both ends.

The extra male DB25 connector & case are provided for the power supply & inputs as described in the documentation.

COMPONENTS KIT 118	
0.1 104 monoblok	C1 C2 C3 C5 4
0.01uF 103 monoblok ...	C6 1
1/8W 5% resistor	
1K brown black red	R5 1
10K brown black orange	R2 1
10R brown black black	.R1 1
1N4148 diode	D1 1
4.7uF/16V tantalum	C4 1
10uF/16V tantalum	C7 1
4K7 resistor network	R3 R4 2
74HCT373	U1 1
78L05	Q1 1
220pF capacitor	C8 1
MAX186	U2 1
K118 PCB	1
D shell snap set	1set
Male 25 pin PCB connector 2
Female 25 pin PCB connector 1
DB25 shell case	1

You may direct questions to

frank@ozitronics.com

See our other kits at

<http://kitsrus.com>

KIT 118 12BIT DATA ACQUISITION SYSTEM

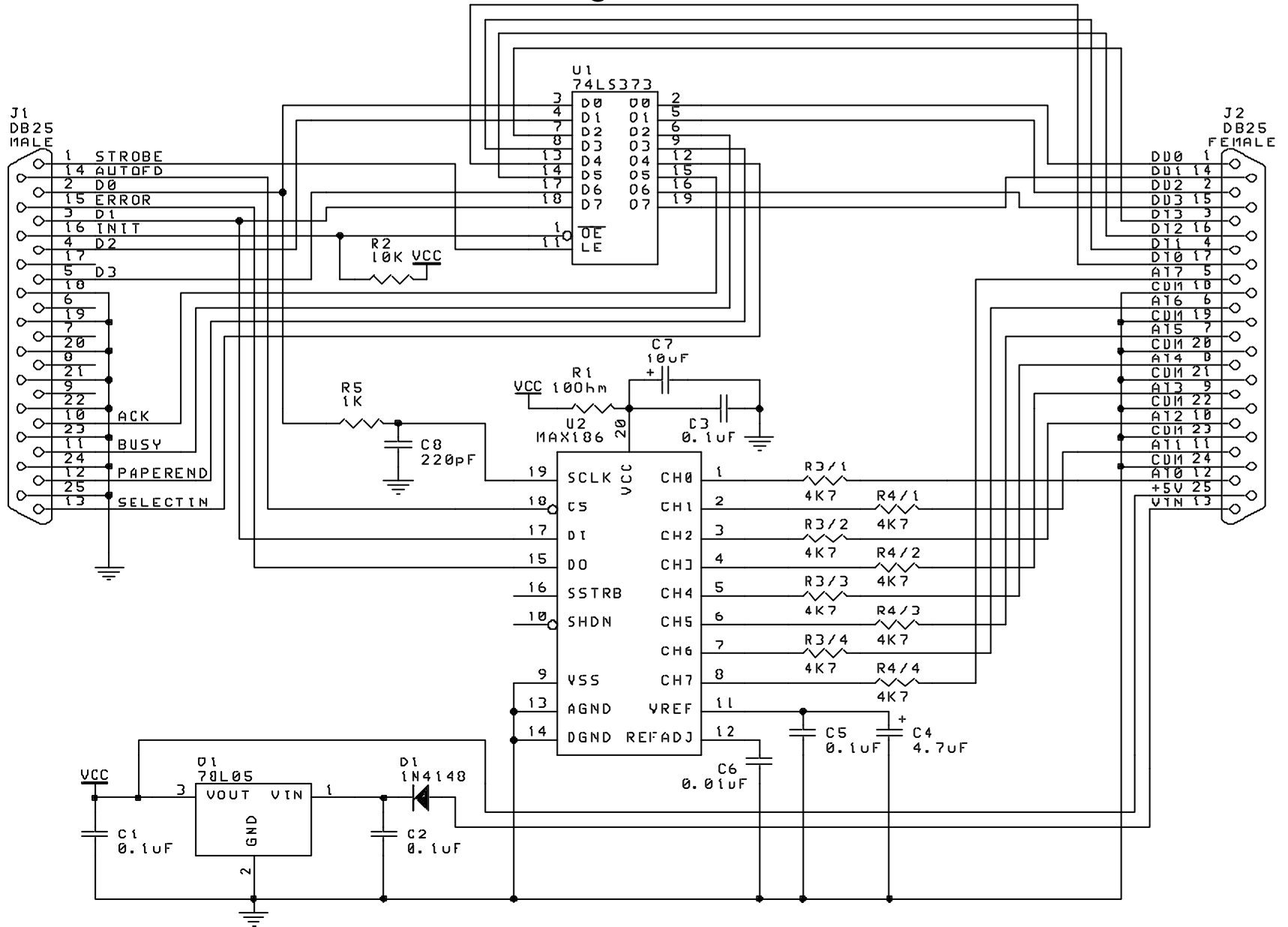

KIT 118 12BIT DATA ACQUISITION SYSTEM