

RRTT - SERIES

ASSEMBLY INSTRUCTIONS FOR
TABLE TOP RELAY RACK RRTT1921, RRTT1928

BUL10247
REV. A
PAGE 1 OF 1

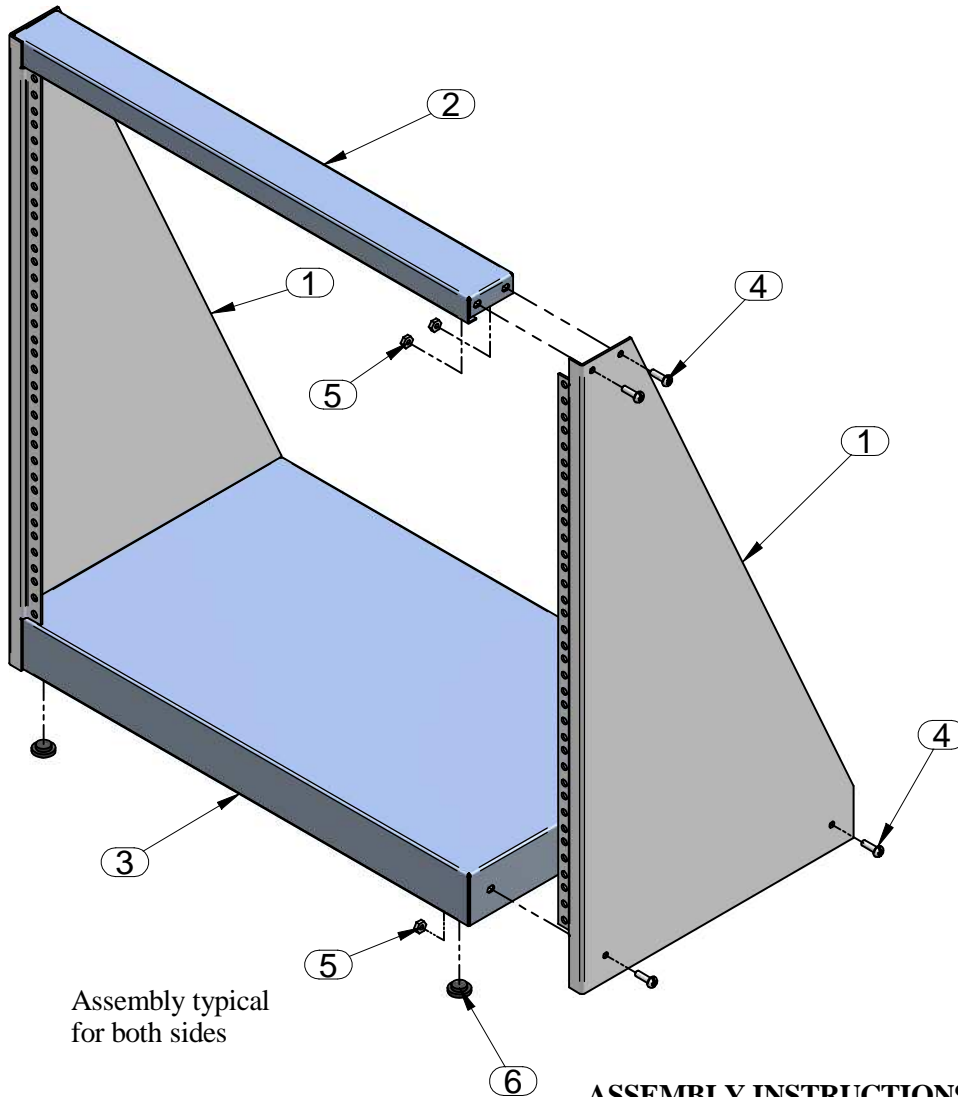

ASSEMBLY INSTRUCTIONS:

- Assemble right and left sides (item 1) to the top (item 2) and to the bottom (item 3) as shown.
- Secure the sides to the top and bottom using the 10-32 hardware thru assembly holes in sides and the corresponding holes in the top and bottom.
- Hand tighten the assembly. Then square the rack and tighten hardware fully.
- Mount the rubber feet (item 6) on bottom. Push retainer end of the feet thru holes provided on bottom flanges.

PARTS LIST

ITEM No.	DESCRIPTION	QTY
1	RIGHT AND LEFT SIDES	2
2	TOP	1
3	BOTTOM	1
4	10-32 PHILLIPS PAN HD	8
5	10-32 KEP NUTS	8
6	PUSH ON RUBBER FEET	4

TOOL BOX



#2 Phillips
Screw Driver



Square



HAMMOND
MANUFACTURING™
ELECTRONICS GROUP

visit our website @ www.hammondmfg.com